

VIRTUS™ MULTI-PURPOSE CONNECTOR (MPC)

Low-cost connection system for flying leads and jumper umbilicals

The AFGlobal Multi-Purpose Connector (MPC) is a diverless, fly-to-place connection system specially designed for flying leads and jumper umbilicals. Fully adaptable to all hydraulic, electrical, or chemical couplers from any vendor, the MPC has built a 20-year track record as a reliable, low-cost connection solution—with more than 1,000 systems deployed in fields worldwide.

APPLICATIONS:

- Provides the means to connect flying leads and umbilicals between subsea hardware including PLEMS, Christmas Trees, Manifolds, and Umbilical Termination Assemblies (UTAs)
- Can be configured as a chemical-injection crossover plate or to carry retrievable instrumentation packs or flowmeter differential pressure cells
- Provides electric, hydraulic, and mechanical interface for AFGlobal subsea control module installation

BENEFITS AND DIFFERENTIATORS:

- Simple design with configurable inboard and outboard terminations capable of housing a combination of electrical connectors, sensors and hydraulic couplings
- Termination coupling provided by AFGlobal's Retlock® Connector, which incorporates a shear pin safety override that enables diver-less disconnect and recovery in emergency situations
- Housed in a compact assembly, which minimizes the real estate required on the host structure
- Affords a high degree of coupler flexibility. MPCs can be supplied without couplers or populated with electrical or hydraulic couplers, as the application dictates
- Coupler interface plates are fully configurable to meet operational requirements.
- Optional built-in protection feature allows controlled breakaway of the flying lead in the event of an accidental loading event such as a trawler or umbilical snag. This feature protects the inboard structure and enables subsequent ROV intervention
- Is installable by workclass ROVs with simple tooling that is available for sale or rent

ITEM	DESCRIPTION
1	Inboard Assembly
2	Outboard Assembly
3	Class 4 Torque Receptacle
4	Flying Lead Breakaway 'Weak link' (Optional)
5	Flying lead Support Tube (Optional)
6	ROV Handles (Optional)
7	Coarse Alignment Funnel
8	Fine Alignment Pins
9	Hydraulic Couplers
10	Electrical Connectors (Optional)
11	Flying Lead Orientation Tool (Optional)

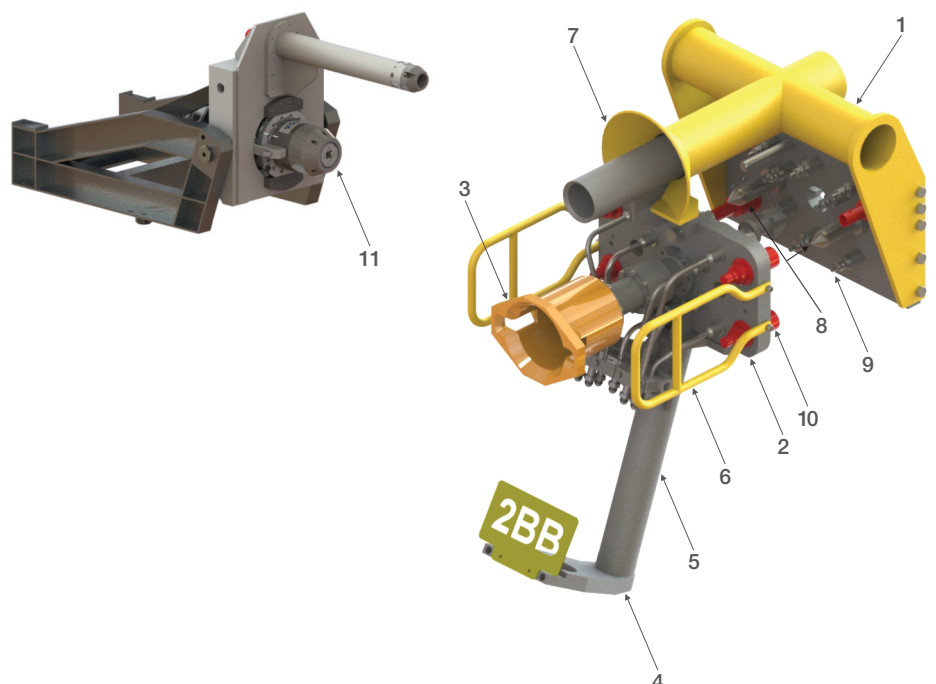

TECHNICAL SPECIFICATIONS

TORQUE REQUIREMENTS					
Running	Make-Up	Break-Out	Shear	Tool Class	Turns (Fully Open to Fully Closed)
89 ft-lb (120Nm)	406 ft-lb (550Nm)	443 ft-lb (900Nm)	664 ft-lb (900Nm)	API 17D Class 4	26

COUPLER CONFIGURATION
The standard plate currently allows any 14 way configuration of hydraulic couplers/electrical connectors/sensors. Combinations with higher numbers are available on request.

MAXIMUM SEPARATION LOAD
14.6T (13.2Te)

MATERIALS		
Retlock Shaft	Main Plate	Alignment System
AISI 4140	15ksi Structural Steel (Stainless Steel Option)	15ksi Structural Steel

DIMENSIONS & WEIGHTS

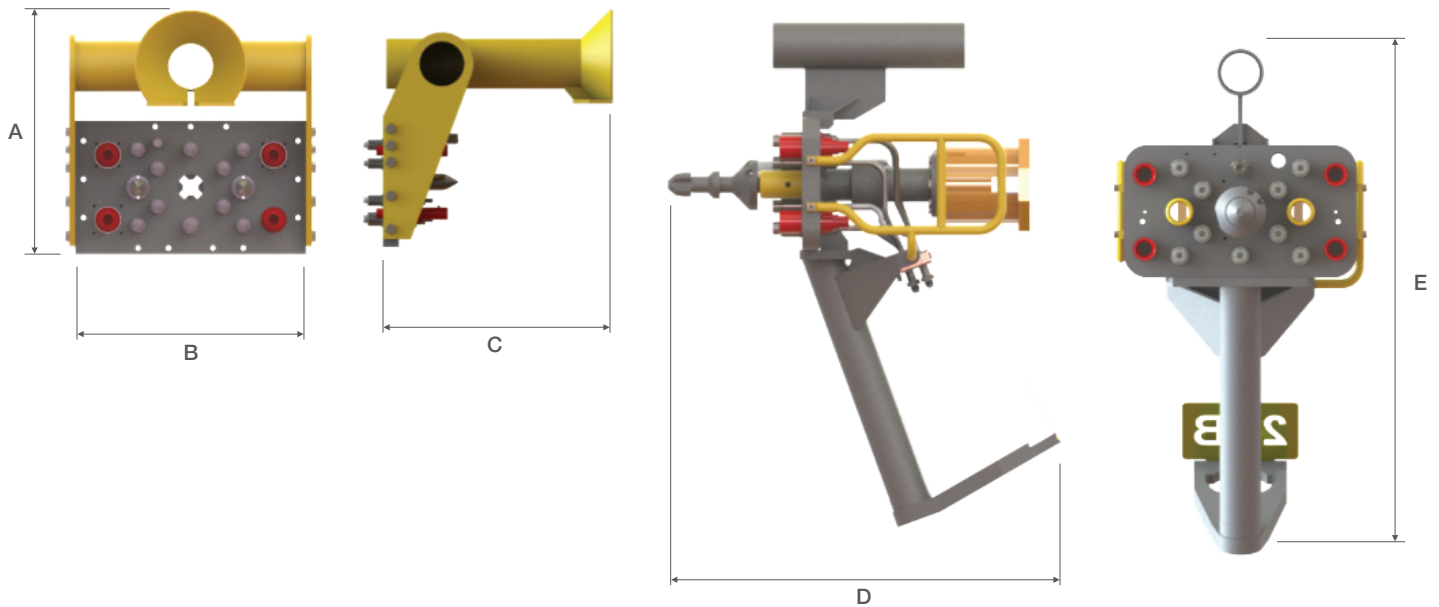

TORQUE REQUIREMENTS						
A	B	C	D	E	Outboard Weight Dry (Excluding Support Tube)	Outboard Weight In Water (Excluding Support Tube)
23.8-in (605mm)	13.0-19.7-in (330-500mm)	22.8-in (580mm)	29.5-in (750mm)	48.8-in (1240mm)	247 lbs (112kg)	209 lbs (95kg)



945 Bunker Hill, Suite 500 | Houston, Texas 77024 USA | 713-393-4200

afglobalcorp.com